

Model WS™ — 5.6 K-factor Specific Application Window Sprinklers, Horizontal and Pendent Vertical Sidewall

General Description

The Model WS, 5.6 K-factor, Horizontal Sidewall and Pendent Vertical Sidewall, Specific Application Window Sprinklers are fast response, glass bulb type spray sprinklers.

These sprinklers are the first sprinklers ever to be specifically Listed to provide protection for heat strengthened or tempered glass windows using closed sprinklers. As part of the testing, the gas flow required to achieve the time/temperature relationship specified in ASTM E119 was established in a test furnace without sprinkler protection. A window assembly protected with Model WS Specific Application Window Sprinklers was then installed in the test furnace and the same gas flow conditions were maintained for a two hour test period. No cracking or visible damage to the window was permitted during the test period (even when a hose stream was directed at the window).

The success of the Model WS Specific Application Window Sprinkler is based on its specially designed deflector that ensures that the spray pattern wets the entire surface of the window, and its fast response thermal sensitivity.

Based on this successful testing, the Model WS Specific Application Win-

dow Sprinkler can be used as interior protection of windows or glazing in a sprinklered building or non-sprinklered building. Also, the Model WS Specific Application Window Sprinkler can be used as an open sprinkler for "Outside Sprinkler Protection against Exposure Fire", using the design requirements of NFPA.

As with any specific application sprinkler, the installation instructions included in this data sheet must be precisely followed. ICC Evaluation Service, Underwriters Laboratories of Canada (ULC), or Building Materials Evaluation Commission (BMEC) guidelines apply, consult the specific approval report.

WARNING

The Model WS Specific Application Window Sprinklers described herein must be installed and maintained in compliance with this document, as well as with the applicable standards of the National Fire Protection Association, in addition to the standards of any other authorities having jurisdiction. Failure to do so may impair the performance of these devices.

The owner is responsible for maintaining their fire protection system and devices in proper operating condition. The installing contractor or manufacturer should be contacted with any questions.

Sprinkler Identification Number

**TY3388 - Horizontal Sidewall
TY3488 - Pendent Vertical Sidewall**

TY3388 is a redesignation for C3388.
TY3488 is a redesignation for C3488.



IMPORTANT

Always refer to Technical Data Sheet TFP700 for the "INSTALLER WARNING" that provides cautions with respect to handling and installation of sprinkler systems and components. Improper handling and installation can permanently damage a sprinkler system or its components and cause the sprinkler to fail to operate in a fire situation or cause it to operate prematurely.

Technical Data

Approvals

UL, C-UL, and ULC Listed.
 NYC under MEA 289-04-E.
 (The approvals only apply to the service conditions indicated in the Design Criteria section.)

Additional Recognition

- ICC Evaluation Service (ICC-ES Legacy Report NER-516)
- Building Materials Evaluation Commission (BMEC 01-11-263)

Pipe Thread Connection

1/2 inch NPT

Discharge Coefficient

$K = 5.6 \text{ GPM/psi}^{1/2}$
 (80,6 LPM/bar^{1/2})

Temperature Rating

155°F/68°C & 200°F/93°C

Finish

Polyester Coated, Chrome Plated, or Natural Brass

Physical Characteristics

Frame	Brass
Button	Bronze/Copper
Sealing Assembly	
.	Beryllium Nickel w/Teflon†
Bulb	Glass (3 mm dia.)
Compression Screw	Brass
Deflector	Brass/Bronze
†	DuPont Registered Trademark

The glass bulb contains a fluid that expands when exposed to heat. When the rated temperature is reached, the fluid expands sufficiently to shatter the glass bulb, allowing the sprinkler to activate and water to flow.

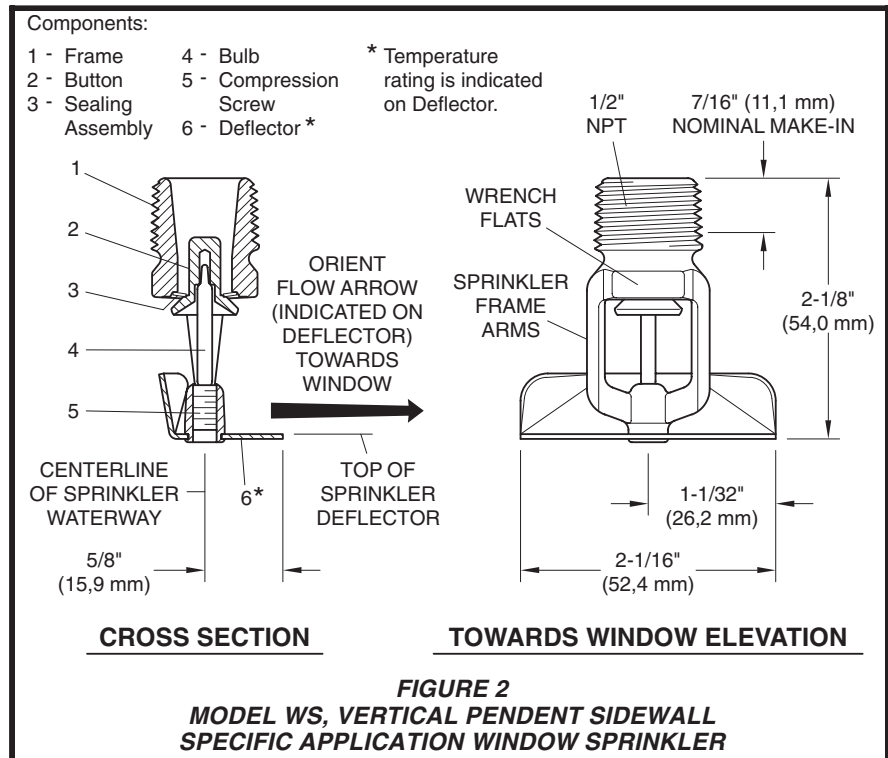
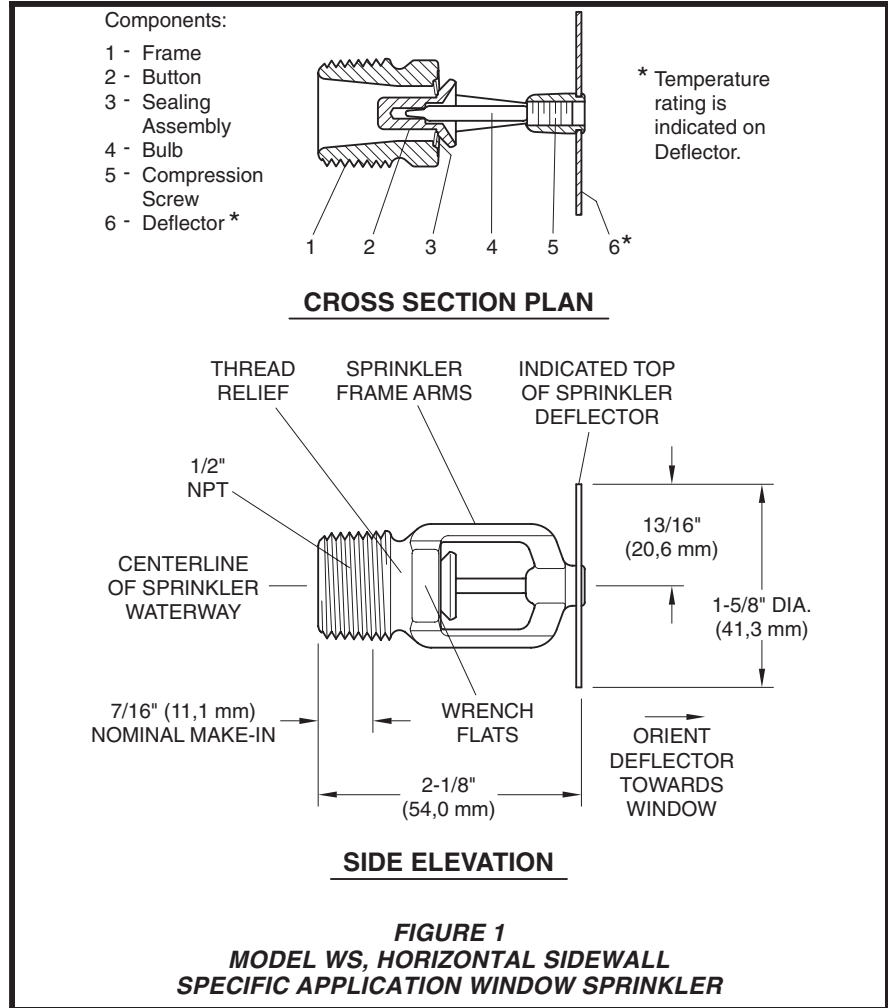

Design Criteria

The Model WS Window Sprinklers are listed by UL and C-UL, and NYC Approved (MEA 335-01-E) for use as a "Specific Application Window Sprinkler" and as open sprinklers for "Outside" use. These sprinklers are also recognized by the International Code Council Evaluation Service, Underwriters Laboratories of Canada (ULC), and the Building Materials Evaluation Commission (BMEC) for use in the Province of Ontario, Canada as providing a two-hour equivalency for a fire separation assembly, when installed in accordance with the NES Report (NER 516), ULC/ORD-C263.1 Appendix A, and BMEC Report (01-11-263).

NOTE

NER 516 can be obtained at www.icc-es.org. ULC/ORD-C263.1 Appendix A and BMEC 01-11-263 may be obtained by contacting Technical Services.

Area Of Use:

When acceptable to the Authority Having Jurisdiction and unless modified by one of the reports mentioned above, the Model WS Specific Application Window Sprinklers may be used in either a sprinklered or unsprinklered building to protect nonoperable window openings that are part of a fire separation provided:

- in an interior fire separation, the window sprinklers are installed on both sides of the window in the fire separation. (Ref. Figure 3A-1),
- in jurisdictions where exterior spatial separation (i.e., separation from adjacent space) is defined as protecting an adjacent building from a fire in your building, window sprinklers are installed on the interior side of the building (Ref. Figure 3A-2), or
- in jurisdictions where exterior spatial separation is defined as protecting your building from a fire in an adjacent building (i.e., exposure protection), open window sprinklers are installed on the exterior side of the building (Ref. Figure 3A-3).

System Type:

Interior Protection - Wet Systems.

Outside Exposure Protection - Deluge.

Glass Type:

Non-opererable, heat-strengthened, tempered, single-glazed (single pane); non-opererable, heat-strengthened, tempered, double-glazed (double pane or insulated); or, non-opererable, stronger glass window assemblies. In all three cases, each individual pane of the window assembly is to be minimum 6 mm (1/4") thick.

Type of Window Frame/Mullion:

Noncombustible Frame with a standard EPDM rubber gasket seal. Vertical joints of glass panes must be connected by butt-joints sealed with a silicone sealant between the individual panes or by Noncombustible Mullions (Ref. Figure 3B-1 & 3B-2).

Maximum Length Of Window Assembly:

Unlimited.

Maximum Height Of Window Assembly:

13' (3,96 m) (Ref. Figure 3C & 3D).

Maximum Distance Between Window Sprinklers:

8' (2,44 m) (Ref. Figure 3B-1 & 3B-2).

Minimum Distance Between Window Sprinklers:

6' (1,83 m) (Ref. Figure 3B-1 & 3B-2), unless separated by a baffle or mullion of sufficient depth to act as a baffle. (A mullion will act as a baffle, when in the case of the Pendent Vertical Sidewall, the mullion extends to the back of the sprinkler deflector, and in the case of the Horizontal Sidewall, the mullion extends to the sprinkler wrench flat.)

Minimum Distance From Standard Sprinklers:

6' (1,83 m) unless separated by a baffle.

Sprinkler Location:

Mullioned Glazing Assemblies - Locate window sprinklers within each mullioned glazing segment (Ref. Figure 3B-1).

Butt Jointed Glazing Assemblies - Locate window sprinklers on maximum 8' (2,44 m) centers (Ref. Figure 3B-2).

Maximum Distance From Vertical Mullion:

4' (1,22 m) (Ref. Figure 3B-1).

Minimum Distance From Vertical Mullions:

4" (101,6 mm) (Ref. Figure 3B-1).

Intermediate Horizontal Mullions:

Intermediate Horizontal Mullions were not tested with the window sprinkler. Their use is outside the scope of the "Specific Application" Listing for the window sprinklers (Ref. Figure 3B-3).

Deflector Location:

Sprinkler Deflectors must be located as described below in order to ensure that the entire surface of the glass window is covered. Sprinkler Deflectors are positioned with respect to the window frame, not the ceiling.

Horizontal Sidewall - Locate within the outside edge of the window frame from 1/2" to 4" (12,7 mm to 101,6 mm) away from the glass and 2" ± 1" (50,8 mm ± 25,4 mm) down from the top of exposed glass (Ref. Figure 3C).

Pendent Vertical Sidewall - Locate 4" to 12" (101,6 mm to 304,8 mm) from the face of the glass and 3" ± 1" (76,2 mm ± 25,4 mm) down from the top of exposed glass (Ref. Figure 3D).

Minimum Clearance From Face Of Glass To Combustible Materials:

All combustible materials shall be kept 2" (50,8 mm) from the front face of the glass. This can be accomplished by a minimum 36" (914,4 mm) pony wall or other method acceptable to the Authority Having Jurisdiction.

Escutcheon Assemblies:

The window sprinklers can be used with any metallic flush or extended escutcheon, provided the dimensions from the sprinkler deflector to the window frame and glass surface as specified in this data sheet are maintained. These sprinklers are not listed for recessed applications.

Recommended Hydraulic Requirements:

The Authority Having Jurisdiction should be consulted to determine the hydraulic requirements for each installation.

Interior Protection Sprinklered Building - Identify which compartmented area has the most hydraulically demanding window sprinklers. Calculate all of the sprinklers within a compartmented area or the number of window sprinklers required to cover a combined linear length of glass equal to 1.2 x the square root of the system area of operation, whichever is greater. For example if the building design area is 1500 ft² then 1.2 x (1500 ft²)^{1/2} = 46.5 linear feet of glass or 1.2 x (139 m²)^{1/2} = 14,2 linear meters of glass. Add the window sprinkler demand to your most demanding hydraulic design area.

Interior Protection Non-Sprinklered - Calculate all the sprinklers on the most demanding side of the glazing assembly within the enclosure.

Exterior Exposure Protection - Calculate all sprinklers controlled by the deluge valve using the design requirements of NFPA.

Duration Of Water Supply:

The duration of the water supply must comply with the requirements of NFPA. In the event the window sprinklers are being used to provide the equivalency of a fire rating, the water supply must be capable of supplying water for the required rating period.

Minimum Flow Per Sprinkler:

20 GPM (75,7 LPM) for sprinkler spacing of 6 to 8 ft. (1,83 to 2,44 m) or 15 GPM (56,8 mLPM) for sprinkler spacing less than 6 ft. (1,83 m).

Maximum Pressure Per Sprinkler:

Horizontal Sidewall = 70* psi (4,83 bar).

Vertical Sidewall = 175 psi (12,07 bar).

*The 70 psi is only for cold solder purposes. If there is a baffle or mullion of sufficient depth to act as a baffle, separating the sprinklers, the maximum pressure is 175 psi.

Installation

The Model WS Specific Application Window Sprinklers must be installed in accordance with the following instructions:

NOTES

Do not install any bulb type sprinkler if the bulb is cracked or there is a loss of liquid from the bulb. With the sprinkler held horizontally, a small air bubble should be present. The diameter of the air bubble is approximately 1/16 inch (1,6 mm).

A leak tight 1/2 inch NPT sprinkler joint should be obtained with a torque of 7 to 14 ft.lbs. (9,5 to 19,0 Nm). A maximum of 20 ft.lbs. (28,5 Nm) of torque is to be used to install sprinklers. Higher levels of torque may distort the sprinkler inlet with consequent leakage or impairment of the sprinkler.

Step 1. The pendent vertical sidewall sprinkler must be installed only in the pendent position with the centerline of the sprinkler parallel to the glass surface. The sprinkler must be orientated so that the direction of flow indicated on the sprinkler deflector is facing the window. The horizontal sidewall sprinkler must be installed only in the horizontal position with the centerline of the sprinkler perpendicular to the glass surface. The sprinkler must be orientated so that the word "Top" indicated on the sprinkler deflector is facing the top of window frame.

Step 2. With pipe thread sealant applied to the pipe threads, hand tighten the sprinkler into the sprinkler fitting.

Step 3. Wrench tighten the Sprinkler using only the W-Type 20 (End A) Sprinkler Wrench (Ref. Figure 4). The W-Type 20 (End A) Sprinkler Wrench is to be applied to the Sprinkler Wrench flats only.

When acceptable to the Authority Having Jurisdiction the Model WS Specific Application Window Sprinklers may be used in either a sprinklered or unsprinklered building to protect nonoperable window openings that are in an interior fire separation, the window sprinklers are installed on both sides of the window in the fire separation.

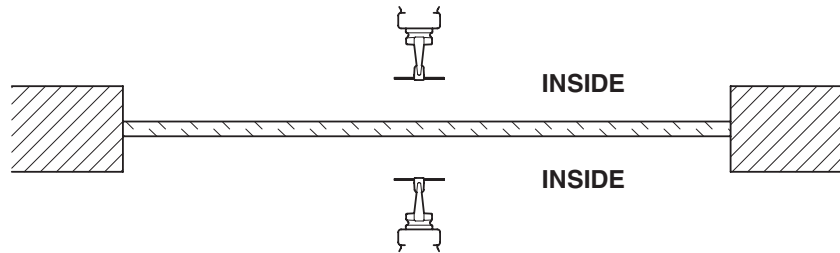

FIGURE 3A-1 — INTERIOR FIRE SEPARATION

When acceptable to the Authority Having Jurisdiction the Model WS Specific Application Window Sprinklers may be used in either a sprinklered or unsprinklered building to protect nonoperable window openings that are part of a fire separation provided in jurisdictions where exterior spatial separation is defined as protecting an adjacent building from a fire in your building, window sprinklers are installed on the interior side of the glass.

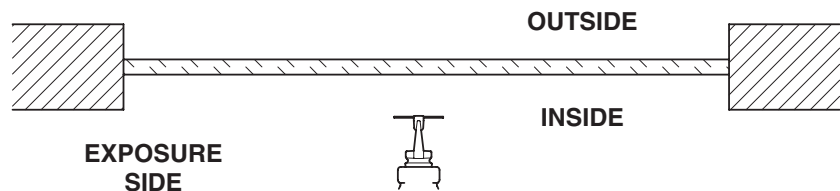

FIGURE 3A-2 — EXTERIOR FIRE SEPARATION — SPRINKLERS INSIDE

When acceptable to the Authority Having Jurisdiction the Model WS Specific Application Window Sprinklers may be used in either a sprinklered or unsprinklered building to protect nonoperable window openings that are part of a fire separation provided in jurisdictions where exterior spatial separation is defined as protecting your building from a fire in an adjacent building, open window sprinklers are installed on the exterior side of the glass.

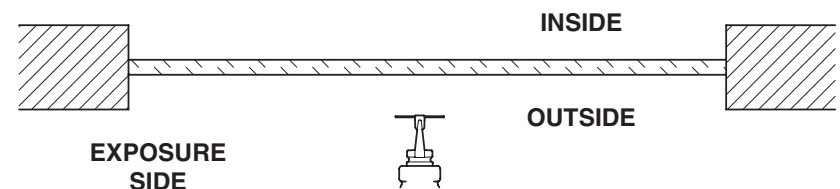
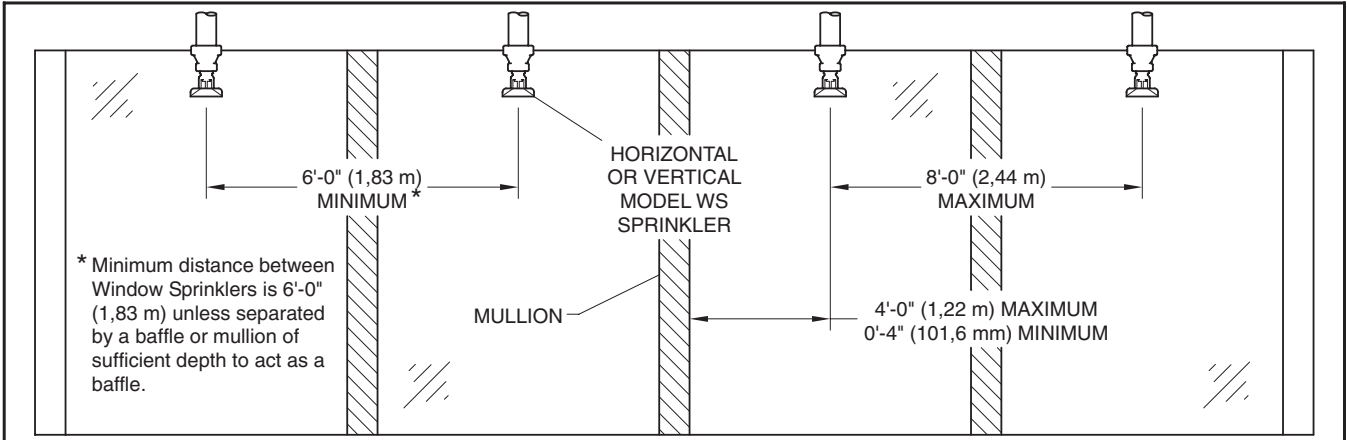

FIGURE 3A-3 — EXTERIOR FIRE SEPARATION — SPRINKLERS OUTSIDE

**FIGURE 3A
TYPICAL NONOPERABLE WINDOW OPENINGS**



A Window Sprinkler must be provided at each window glazing segment, regardless of width of segment. If segment is less than 6'-0", a baffle or mullion to act as a baffle must be provided.

FIGURE 3B-1 — MULTIPLE WINDOWS SEPARATED BY MULLIONS

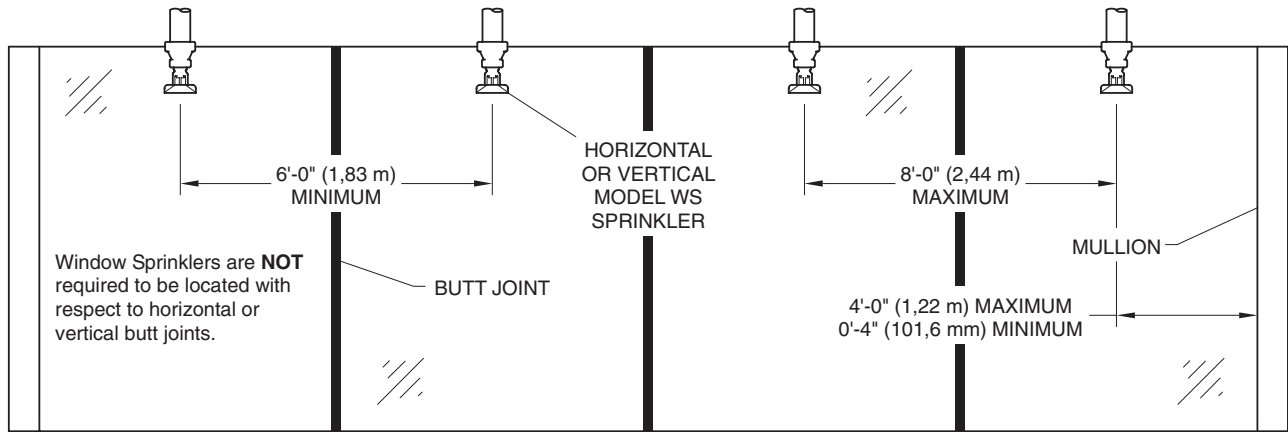

FIGURE 3B-2 — MULTIPLE WINDOWS SEPARATED BY BUTT JOINTS

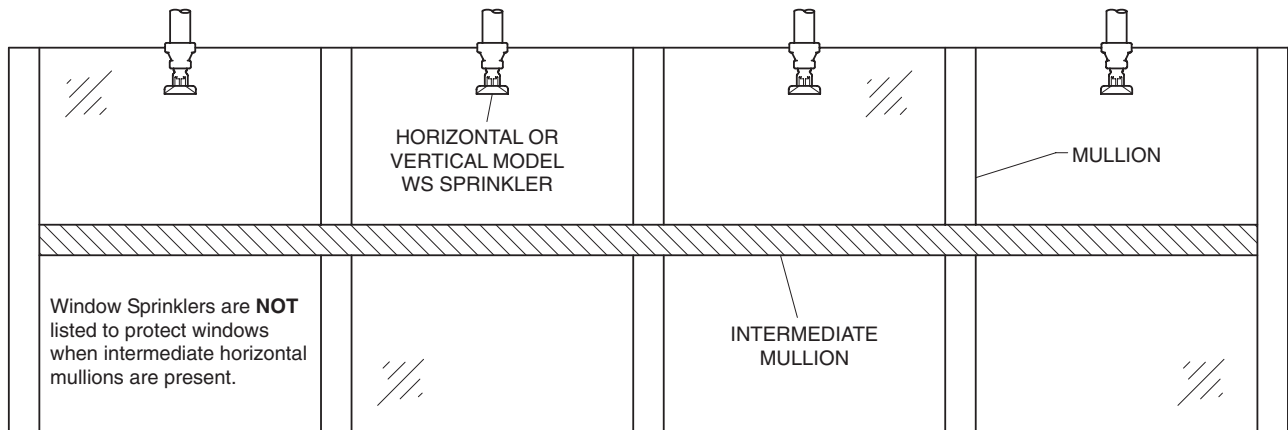

Figure 3B-3 — WINDOWS WITH HORIZONTAL MULLIONS

FIGURE 3B
WINDOW MULLIONS AND BUTT JOINTS

Care and Maintenance

The Model WS Specific Application Window Sprinklers must be maintained and serviced in accordance with the following instructions:

NOTE

Before closing a fire protection system main control valve for maintenance work on the fire protection system that it controls, permission to shut down the affected fire protection systems must be obtained from the proper authorities and all personnel who may be affected by this action must be notified.

Sprinklers that are found to be leaking or exhibiting visible signs of corrosion must be replaced.

Automatic sprinklers must never be painted, plated, coated, or otherwise altered after leaving the factory. Modified sprinklers must be replaced. Sprinklers that have been exposed to corrosive products of combustion, but have not operated, should be replaced if they cannot be completely cleaned by wiping the sprinkler with a cloth or by brushing it with a soft bristle brush.

Care must be exercised to avoid damage to the sprinklers - before, during, and after installation. Sprinklers damaged by dropping, striking, wrench twist/slippage, or the like, must be replaced. Also, replace any sprinkler that has a cracked bulb or that has lost liquid from its bulb. (Ref. Installation Section).

The owner is responsible for the inspection, testing, and maintenance of their fire protection system and devices in compliance with this document, as well as with the applicable standards of the National Fire Protection Association (e.g., NFPA 25), in addition to the standards of any other authorities having jurisdiction. The installing contractor or sprinkler manufacturer should be contacted relative to any questions.

It is recommended that automatic sprinkler systems be inspected, tested, and maintained by a qualified Inspection Service in accordance with local requirements and/or national codes.

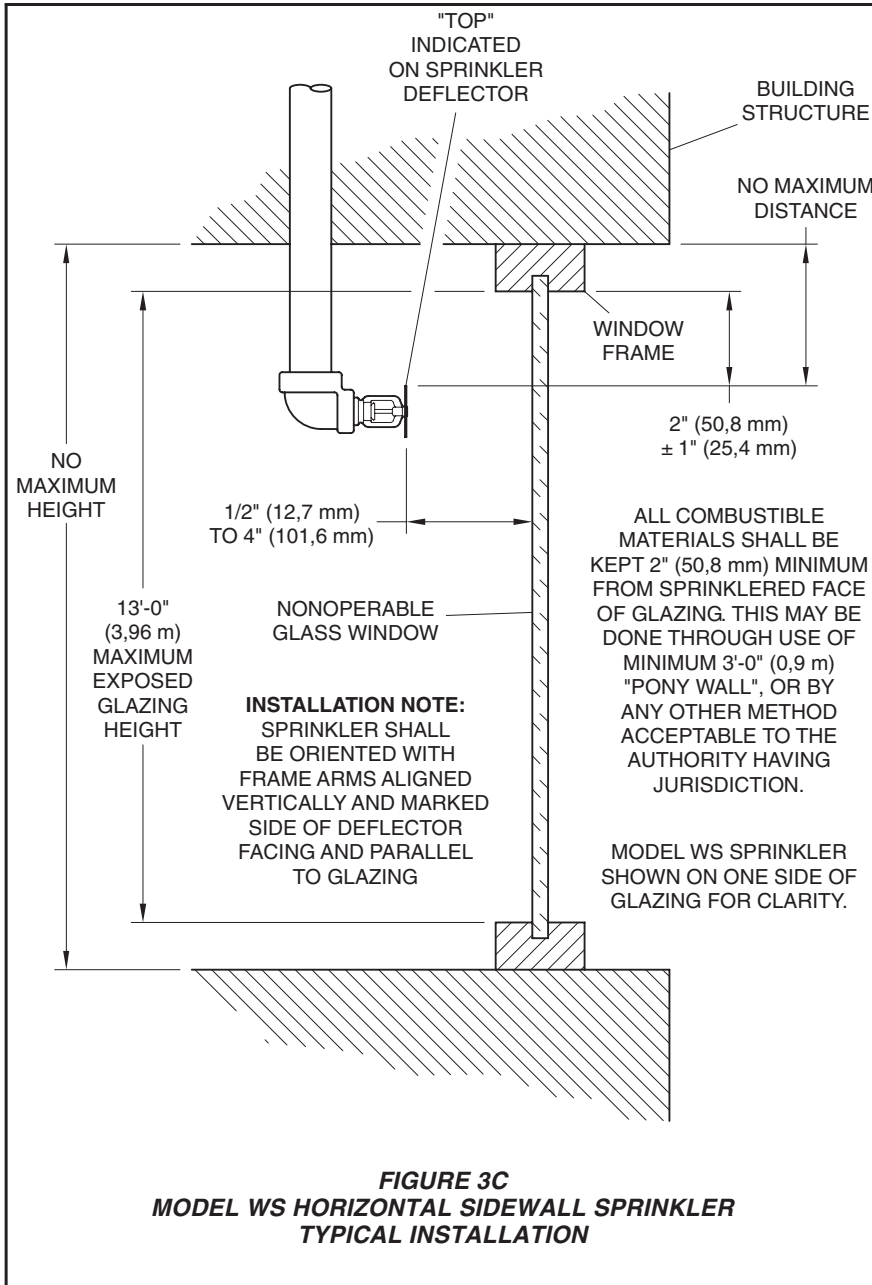

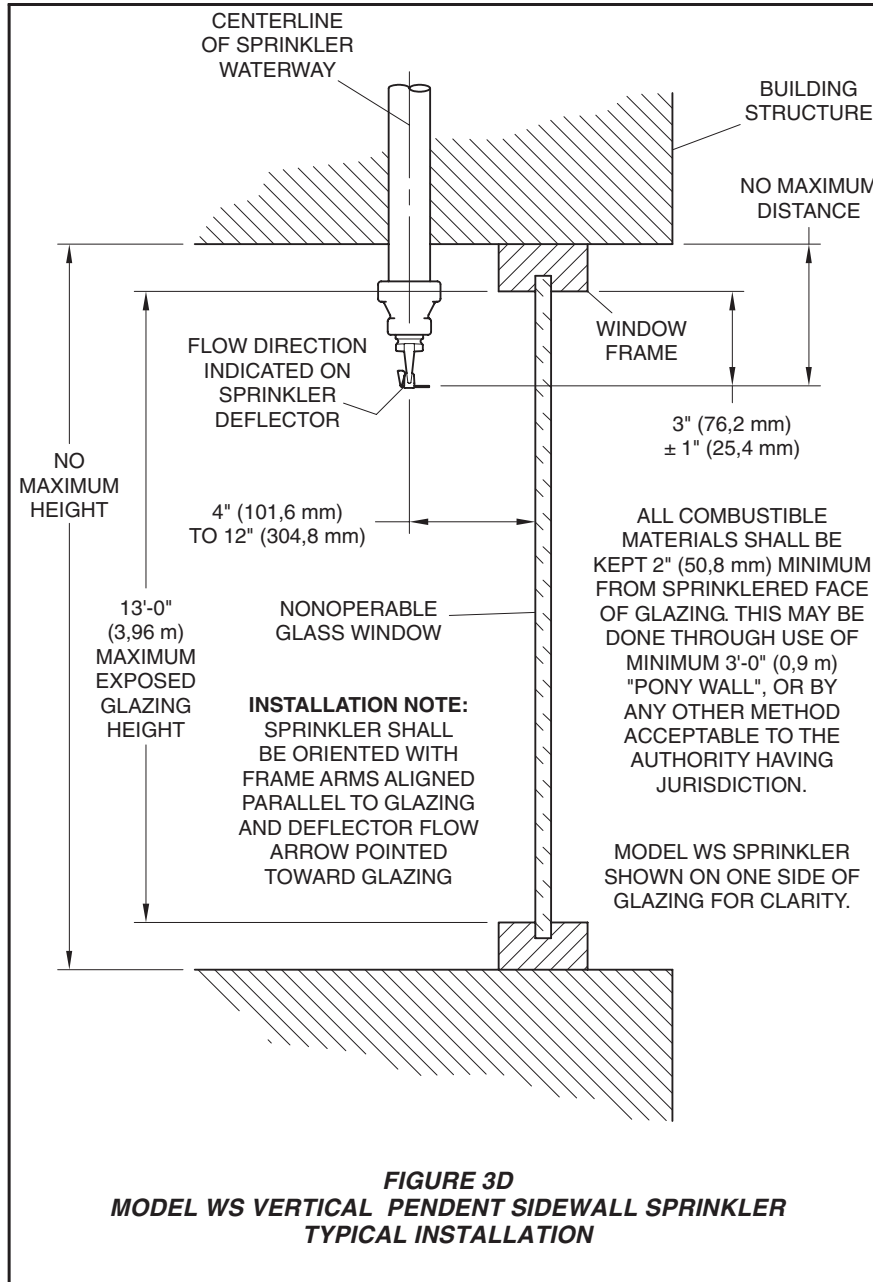

Limited Warranty

Products manufactured by Tyco Fire & Building Products are warranted solely to the original Buyer for ten (10) years against defects in material and workmanship when paid for and properly installed and maintained under normal use and service. This warranty will expire ten (10) years from date of shipment by Tyco Fire & Building Products. No warranty is given for products or components manufactured by companies not affiliated by ownership with Tyco Fire & Building Products or for products and components which have been subject to misuse, improper installation, corrosion, or which have not been installed, maintained, modified or repaired in accordance with applicable Standards of the National Fire Protection Association, and/or the standards of any other Authorities Having Jurisdiction. Materials found by Tyco Fire & Building Products to be defective shall be either repaired or replaced, at Tyco Fire & Building Products' sole option. Tyco Fire & Building Products neither assumes, nor authorizes any person to assume for it, any other obligation in connection with the sale of products or parts of products. Tyco Fire & Building Products shall not be responsible for sprinkler system design errors or inaccurate or incomplete information supplied by Buyer or Buyer's representatives.

IN NO EVENT SHALL TYCO FIRE & BUILDING PRODUCTS BE LIABLE, IN CONTRACT, TORT, STRICT LIABILITY OR UNDER ANY OTHER LEGAL THEORY, FOR INCIDENTAL, INDIRECT, SPECIAL OR CONSEQUENTIAL DAMAGES, INCLUDING BUT NOT LIMITED TO LABOR CHARGES, REGARDLESS OF WHETHER TYCO FIRE & BUILDING PRODUCTS WAS INFORMED ABOUT THE POSSIBILITY OF SUCH DAMAGES, AND IN NO EVENT SHALL TYCO FIRE & BUILDING PRODUCTS' LIABILITY EXCEED AN AMOUNT EQUAL TO THE SALES PRICE.

THE FOREGOING WARRANTY IS MADE IN LIEU OF ANY AND ALL OTHER WARRANTIES EXPRESS OR IMPLIED, INCLUDING WARRANTIES OF MERCHANTABILITY AND FITNESS FOR A PARTICULAR PURPOSE.

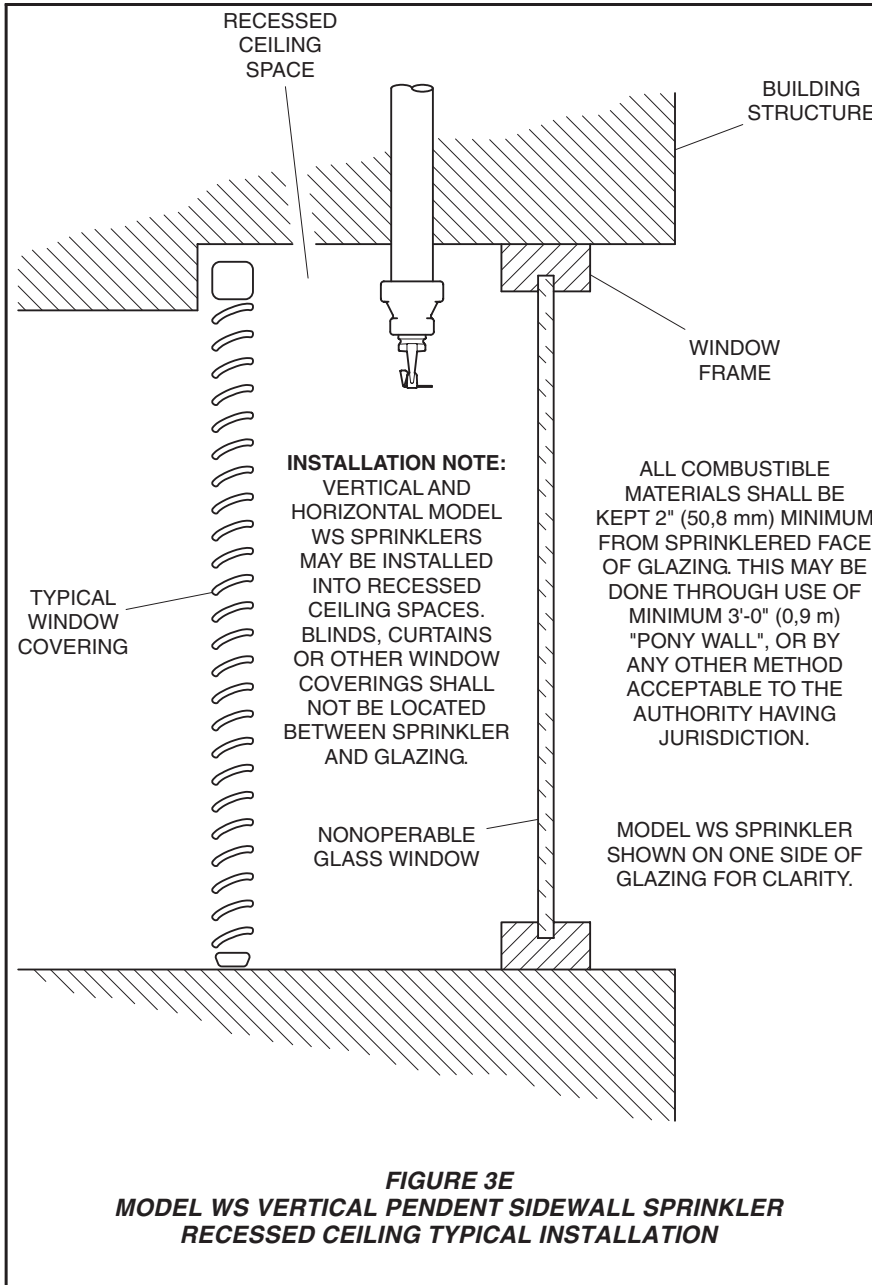

Ordering Procedure

Contact your local distributor for availability.

Sprinkler Assemblies with NPT Thread Connections:

Specify: Model WS, (Specify SIN), (specify Horizontal or Vertical Pendant) Specific Application Window Sprinkler, with (specify temperature rating), (specify finish), P/N (specify).

WS (TY3388) Horizontal Sidewall Window Sprinkler

155°F/68°C, Natural Brass	P/N 50-305-1-155
155°F/68°C, Chrome Plated	P/N 50-305-9-155
155°F/68°C, White Coated	P/N 50-305-4-155
155°F/68°C, White RAL9010*	P/N 50-305-3-155
200°F/93°C, Natural Brass	P/N 50-305-1-200
200°F/93°C, Chrome Plated	P/N 50-305-9-200
200°F/93°C, White Coated	P/N 50-305-4-200
200°F/93°C, White RAL9010*	P/N 50-305-3-200

WS (TY3488) Vertical Pendant Sidewall Window Sprinkler

155°F/68°C, Natural Brass	P/N 50-304-1-155
155°F/68°C, Chrome Plated	P/N 50-304-9-155
155°F/68°C, White Coated	P/N 50-304-4-155
155°F/68°C, White RAL9010*	P/N 50-304-3-155
200°F/93°C, Natural Brass	P/N 50-304-1-200
200°F/93°C, Chrome Plated	P/N 50-304-9-200
200°F/93°C, White Coated	P/N 50-304-4-200
200°F/93°C, White RAL9010*	P/N 50-304-3-200

* Eastern Hemisphere sales only.

Sprinkler Wrench:

Specify: W-Type 20 Sprinkler Wrench, P/N 56-000-1-106.

